

Particle Model of Light Worksheet 2: Pinholes

1. Draw at least ten rays from **one point** on the bulb's surface. Do any reach the viewing screen?

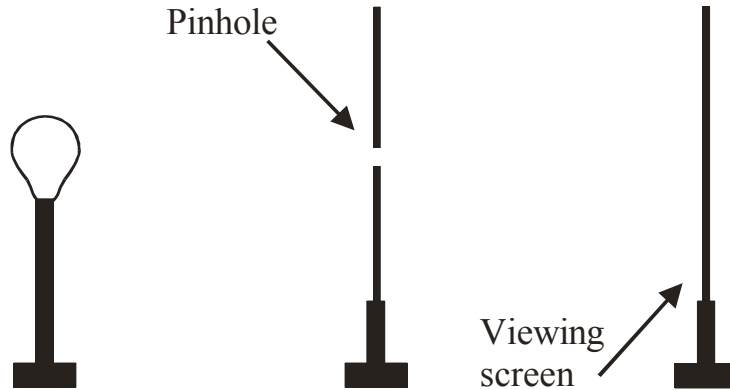

2. Now draw **two rays** (one from top of the bulb, the other from the bottom of the bulb) that travel through the pinhole and reach the screen. Draw several eyes that would be able to see the light that reaches the screen. Explain in words how an inverted reproduction of the bulb is formed on the screen.

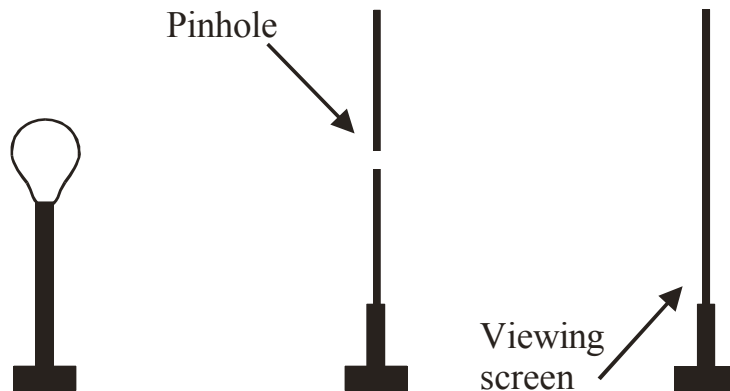

3. Draw a ray diagram and explain in words how the reproduction of the light bulb on the screen changes when the screen is moved closer and farther from the pinhole.

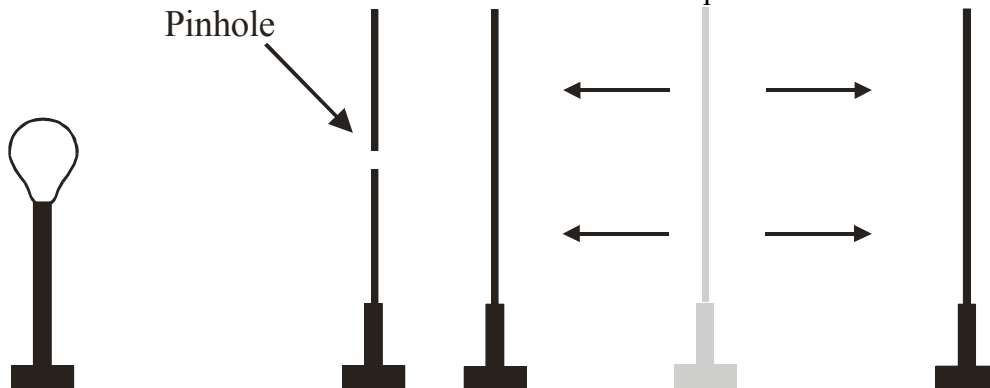

4. What would the eye "see" if the screen were removed? Draw a ray diagram to support your answer.

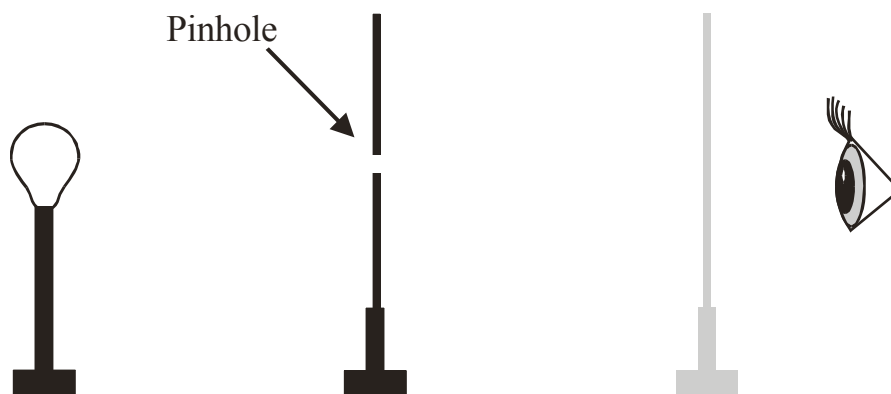

5. From **one point** on the bulb, draw two rays that go through the pinhole (one at the top of the hole, the other at the bottom). Explain in words how increasing the size of the pinhole affects the brightness and sharpness of the bulb reproduction on the screen.

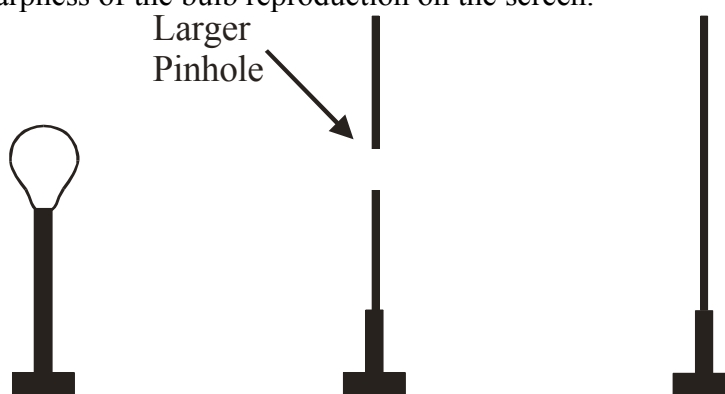

6. Draw rays from the top and bottom of the bulb that travel through each pinhole and reach the screen. Explain how multiple pinholes affect the reproduction of the bulb that is formed on the screen.

